

Tragrolle 506 / 507

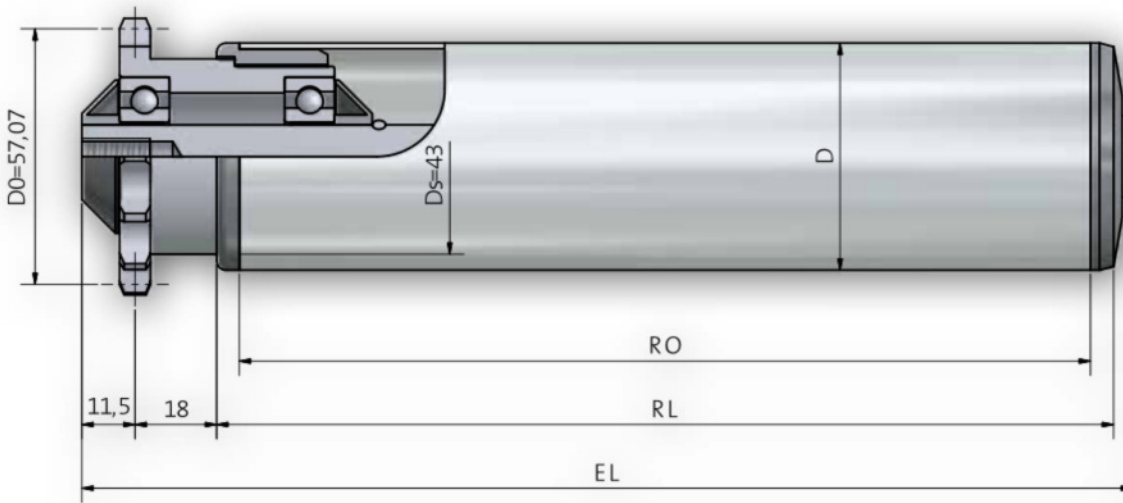

Achsausführungen

| Bestell-Bezeichnung | | A...M... | A...JGM... |
|---------------------|-----|----------|------------|
| Achs- \emptyset | EL= | | |
| 10 | RL+ | 48 | |
| 12 | RL+ | 50 | 36 |
| 14 | RL+ | 52 | 36 |
| 15 | RL+ | 52 | 36 |
| 17 | RL+ | 52 | 36 |

Auswahl Gegenlagertyp für Rohr- und Achskombinationen

| Rohr abm. | A10 | A12 | A14 | A17 |
|-----------------|-----------------|-----------------|-----------------|-----------|
| 50 x 1,5 | 250 / 300 / 302 | 250 / 300 / 302 | 250 / 300 / 302 | 250 |
| 50 x 2 | 250 / 300 | 250 / 300 | 250 / 300 | 250 |
| 50 x 2,8 KB/KGH | 300 | 300 | 300 | |
| 60,3 x 1,65 | 300 | 300 | 300 | |
| 60 x 2 | 250 / 300 / 302 | 250 / 300 / 302 | 250 / 300 / 302 | 250 / 402 |
| 60 x 3 | 250 / 300 | 250 / 300 | 250 / 300 | 250 |
| 63 x 3 KB/KGH | 300 | 300 | 300 | |
| 63,5 x 2,9 | 300 | 300 | 300 | 402 |
| 70 x 2 | 300 | 300 | 300 | |
| 80 x 2 | 250 / 300 | 250 / 300 | 250 / 300 | 250 / 402 |
| 90 x 7 KB/KGH | 300 | 300 | 300 | |

Optional Beschichtungen S. 10

Tragrolle 506 / 507

| | |
|-------------------------|---|
| Antriebs-element | Stahl - Einfachkettenrad 1/2" x 5/16" z=14 |
| Lagerung | Präzisionskugellager (Serie 6202, 6003) nach DIN 625 lieferbar in 2RS, Z, ZZ Standard Serie 6202 ZZ |
| Tragfähigkeit | 1.000N (abhängig von der Belastungsgrenze von Rohr und Achse) |
| max. Geschwindigkeit | 0,3 m/s |
| Temperaturbereich | -5 bis +40 C |
| Antriebsart | Typ 506 Friktionsantrieb mit einem Staudruck ab 5% des Fördergutgewichts Typ 507 Festantrieb wobei das Antriebselement kraftschlüssig über eine Buchse mit dem Rohr verbunden ist. |
| Hinweis | Festantrieb nur bei kontinuierlicher Förderung einsetzen - bei Stop-And-Go Betrieb Typ 508 wählen Bei unebenen Fördergütern einstellbare Staurollen (Typ 506R) einsetzen Förderrollen der Typenreihe 506 auch als Doppelfriktionsrolle Typ 506DF lieferbar. |

Bestellbeispiel

| | |
|-----------------------------|---|
| Typ | 506 ZZ / 300 ZZ - 50x1,5 STI A14 IGM 8x15 EL=700mm |
| Typ Antrieb | 506 ZZ / 300 ZZ |
| Kugellagerabdichtung | ZZ |
| Typ Gegenlager | 50x1,5 |
| Kugellagerabdichtung | STI |
| Rohr-Ø und Wandstärke | A14 |
| Rohrgüte | IGM |
| Achs-Ø | 8x15 |
| Achsende | EL=700mm |
| Einbaulänge | |