

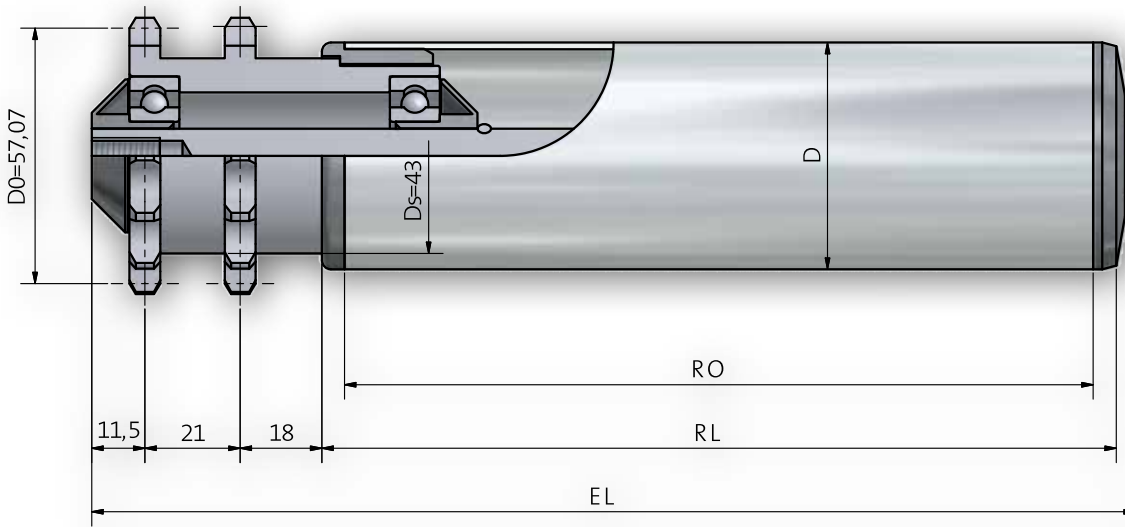

Tragrolle 500 / 501



Achsausführungen

Bestell-Bezeichnung		A...M...	A...JGM...
Achs- \emptyset	EL=		
10	RL+	69	
12	RL+	71	57
14	RL+	73	57
15	RL+	73	57
17	RL+	73	57

Auswahl Gegenlagertyp für Rohr- und Achskombinationen

Rohrabm.	A10	A12	A14	A17
50 x 1,5	250 / 300 / 302	250 / 300 / 302	250 / 300 / 302	301
50 x 2	250 / 300	250 / 300	250 / 300	301
50 x 2,8 KB/KGH	300	300	300	
60,3 x 1,65	300	300	300	
60 x 2	250 / 300 / 302	250 / 300 / 302	250 / 300 / 302	301 / 402
60 x 3	250 / 300	250 / 300	250 / 300	301
63 x 3 KB/KGH	300	300	300	
63,5 x 2,9	300	300	300	402
70 x 2	300	300	300	
80 x 2	250 / 300	250 / 300	250 / 300	301 / 402
90 x 7 KB/KGH	300	300	300	

Optional Beschichtungen S. 10